

# QUICKO

## T12 STC-OLED DIGITAL SOLDERING STATION

### USER MANUAL

VER:1.4@2017618

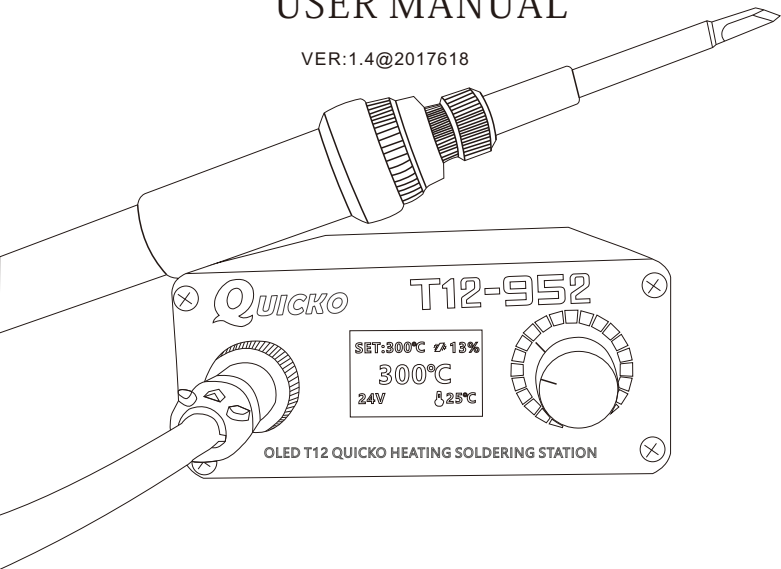

# QUICKO ELECTRONIC.,LTD

<http://www.quickochina.com>

## Conventional safety



Please use only the power adapter that is dedicated to the product and is certified by the country / area.

Do not operate in a wet environment.

Do not operate in a flammable and explosive environment.

Please keep the surface of the product clean and dry.

To protect your family and friends for the safety, please power off after use or leave, beware of fire.

When the host is starting up, the temperature of iron tip will be reached 100°C to 480 °C, beware of scalds.

Do not be soaked in water or with wet hands to use the soldering station, prevent leakage.

## Operating environment

Operating environment	Requirements
temperature	Working condition: +0°C to +50°C
	Off working state: -20°C to +60°C
humidness	Working condition: high temperature 40°C-60°C, 0%-60%RH
	Working condition: low temperature 0°C-40°C, 10%-90%RH
	Off working state: high temperature 40°C-60°C, 5%-60%RH
	Off working state: low temperature 0°C-40°C, 5%-90%RH

## Matters needing attention



When using the T12 iron tip please tighten the nut for soldering head to avoid falling and damaging the iron tip.

The temperature will be reached above 350°C of soldering station is used for 40 minutes, and the temperature of the front end of the handle will be reached 50°C-60°C.

When the new T12 soldering iron tip is used for the first time, Host will appear temperature jump and display ERROR, it will become a normal phenomenon due to the heating of the inner galvanic couple part of the iron tip. After repeated use several times, the temperature will be stabled.

Parts list

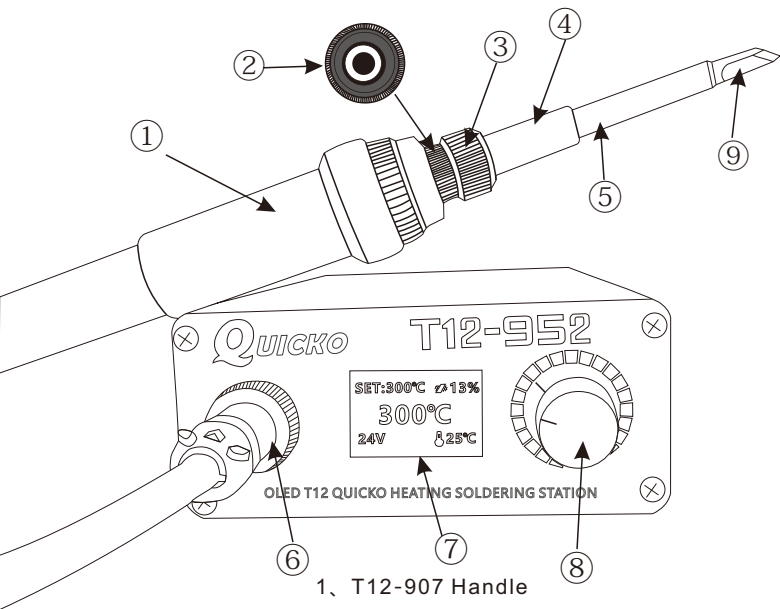

- 1、 T12-907 Handle
- 2、 Socket of iron tip
- 3、 Locking nut for iron tip
- 4、 Lock tube for iron tip
- 5、 Head of iron tip
- 6、 Aviation Plug of handle
- 7、 OLED temperature display
- 8、 Encoder
- 9、 Nozzle tip

## Parts list

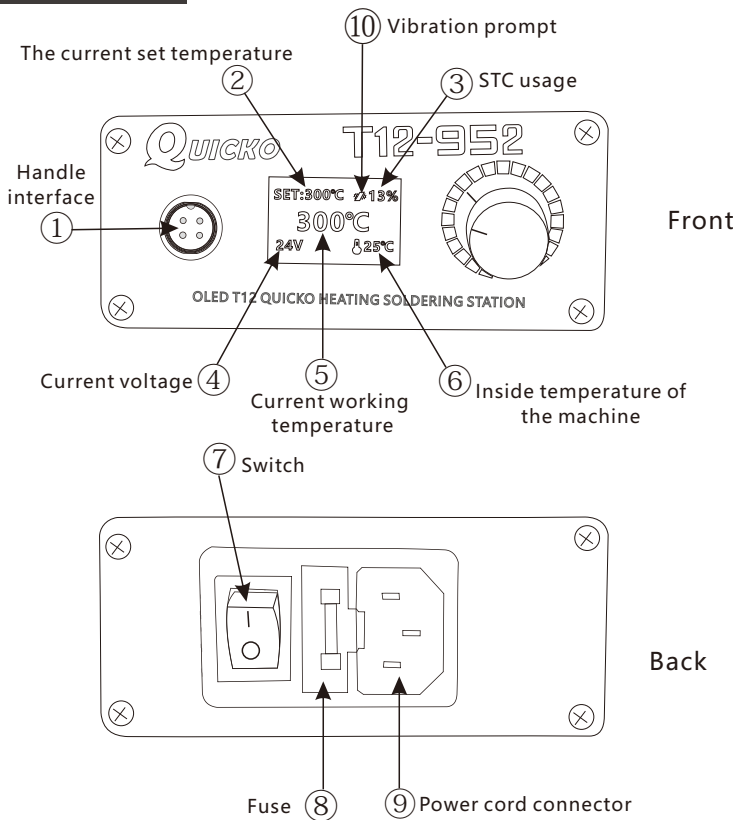

## Product parameter

Model number	T12 STC-952
Display	OLED
Handle interface	GX12-4pins
Product weight	Standard 510g
Dimension of host	120*88*38mm
Wire length of handle	1.1m
Application iron tip	T12 series

## Working parameter

Time of melt tin	<8S
Max power	108W
Range temperature	200-480°C
Voltage of power	24V 4.5A
Input voltage	AC100-240V

## install iron tip

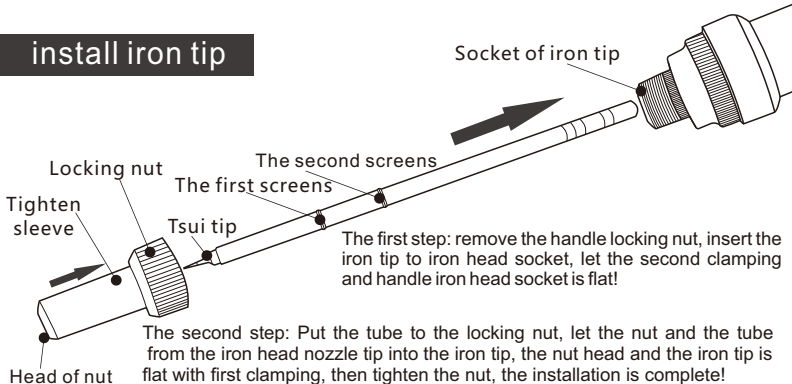

Note: Turn on the button, the display screen shows ERROR, indicating that the iron tip may not be well installed, please try to install the iron tip again.

## Description for display



Initial state of power off



Non plugged iron tip



Normal working state



One press strong temperature

Note: after confirming the installation of the components is right, the new iron tip is inserted into the handle and the display screen will be a flash or ERROR, and the host buzz is wrong. It's normal. After heating 5-20 minutes, it will return to normal gradually. Temperature control range of main engine: 200°C -480 °C. The common welding temperature is 300°C -380°C. In order to protect the working life of the soldering iron tip, it is recommended that the temperature do not more than 380°C!



## Menu use

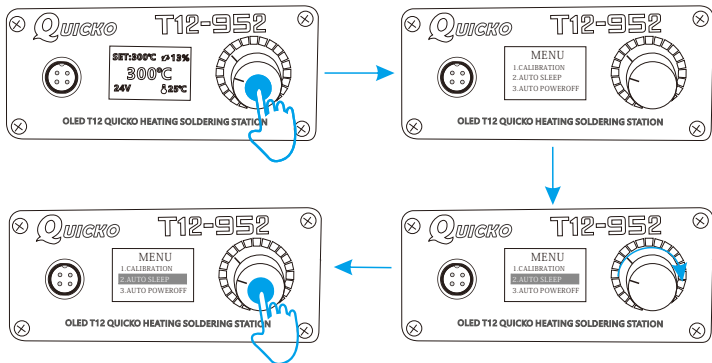

Enter the menu setting interface: under the normal working temperature interface, long press the encoder button (about 3s). Enter the host setup mode! Exit menu settings interface: at the menu setting interface, long press the encoder button (about 3s), exit the host setup mode!

Setting menu:

Enter the function item: rotate the encoder to the corresponding function, and short press the button to enter the function item.

Exit setting function item: after setting the corresponding parameters with the encoder rotary knob, short press the button to confirm exit the function item.

## Temperature calibration

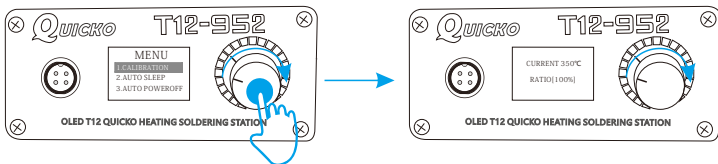

After selecting the temperature calibration function, short press the encoder to enter the temperature calibration setting, the adjustable temperature ratio: 70%-130%, if there is no professional measurement instrument, please set the ratio value to 100%.

## Sleeping time

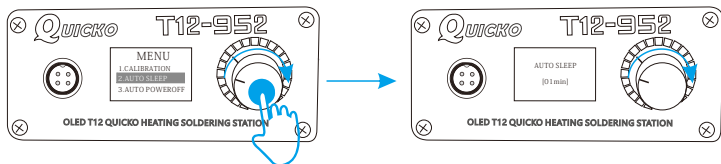

Choosing sleeping time feature, short press encoder, into the sleeping time setting, the time setting range: 0-99 minutes, if you don't need the sleeping time function, the dormancy feature can be set to OFF.

Default sleeping time for 1 minute, means after 1 minute the host and handle is stand still, the soldering station will entry to dormant state, the temperature of soldering iron tip will drop to 150°C, at this time when move handle or rotary encoder, the soldering station will rapidly heat up the working temperature before Sleeping.

You can set the sleeping time according as the usage scenario and working habit, it can be extended the working life of the iron tip and protect your family and friends safe!

## Power off time

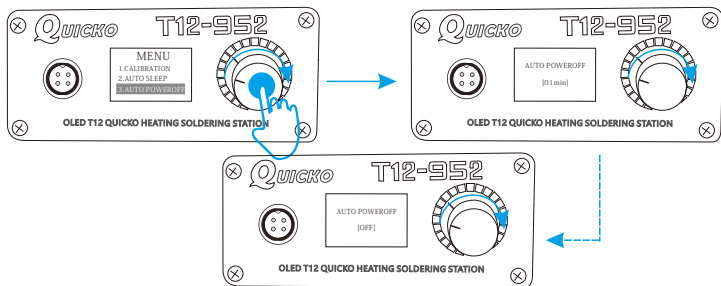

Choosing power off time feature, short press encoder, into the power off time setting, the time setting range: 0-99 minutes, if you don't need the power off time function, the power off function can be set to OFF.

Default power off time for 1 minute, means after 1 minute the host and handle is stand still, the soldering station will entry to power off time state, the temperature of soldering iron tip will drop to indoor temperature (note: The temperature control range of the host is 200-480°C, it will appear larger deviation when the temperature less than 100°C. Please ignore it.). At this time when move handle or rotary encoder, the soldering station will rapidly heat up the working temperature before power off.

You can set the power off time according as the usage scenario and working habit, it can be extended the working life of the soldering iron tip!



## Strengthening time

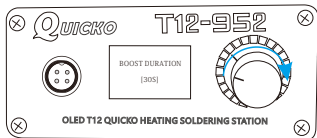
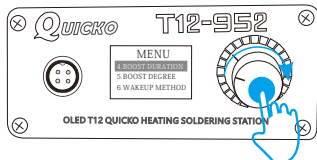

After choosing strengthen the time function, short press the encoder and enter the time setting. The time setting range: 0-99 minutes.

The default time is 30 seconds, it can be set according as the actual needs, after setting, short press the encoder to confirm and exit. When working normally, it takes a short time to increase temperature welding the larger welding spot, it can be heated to the set temperature rapidly after pressing the encoder. After 30 seconds, the host will automatically return to original temperature. This can avoid soldering iron tip oxidation when with high temperature to use!

## Strengthening temperature

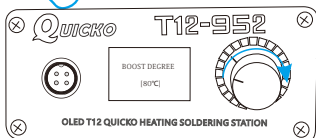
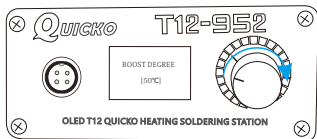
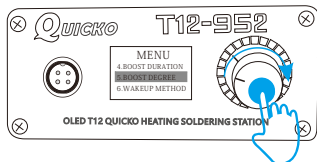

After choosing strengthen the function of temperature, short press the encoder, enter strengthening temperature setting, the temperature setting range: 10-80 °C.

The default strengthen temperature is 30 °C, it can be set according as actual needs, after setting, short press the encoder to confirm and exit. When working normally, it takes a short time to increase temperature welding the larger soldering spot, it can be heated to the set temperature rapidly after pressing the encoder. After 30 seconds, the host will automatically return to original temperature. This can avoid soldering iron tip oxidation when with high temperature to use!

## Wake-Up type

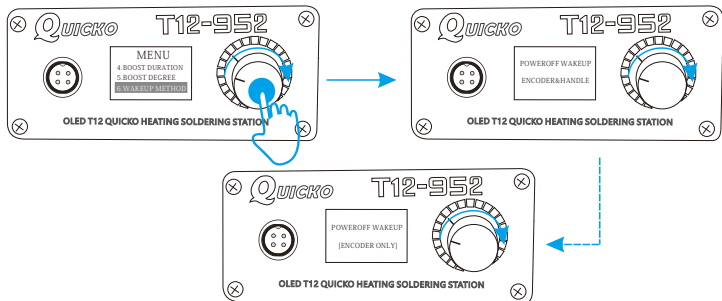

After selecting the wake-up function, short press the encoder, enter setting of wake-up type, the system provides two kinds of wake-up type: encoder together with handle or just encoder. When choosing encoder + handle, the soldering station is automatic power off, shaking handle or short press or rotary encoder, all can wake-up the host!

When choosing the encoder, the automatic shutdown state, short press or rotary encoder can wake-up the host, but shaking handle cannot wake-up the host!

The default setting is: encoder + handle, which can be set according to actual needs.

## Buzzer switch

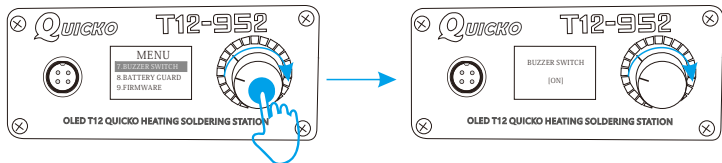

This version OLED controller integrates with a buzzer, and the sound prompts the host state. The buzzer will beep when the host encounters an error or sets the appropriate function.

## Battery guard

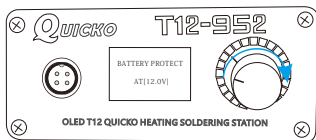
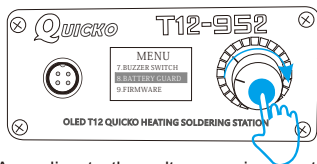

According to the voltage environment of the host, built-in battery guard function of this soldering station, and the default voltage is 12V. When the voltage is not stable, the power supply will be supercharged according to the setting. Usually don't need to set it. The setting range is 12V-24V.

## Version information

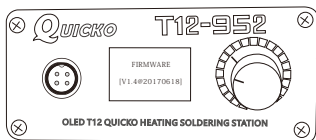
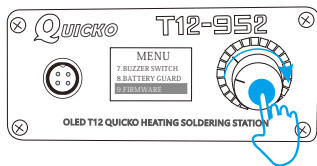

It shows the information of this version controller.

## Restore default

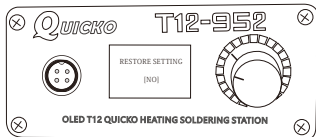
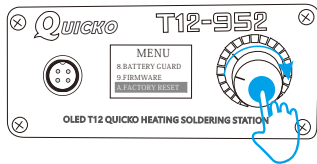

Restore the parameters of the soldering station to the factory default. Note: please back-up your usual important parameters before you restore factory Settings to prevent data loss. For example: temperature calibration value, strengthening time and temperature, etc.

# How to choose the iron tip

Unit: mm

T12-B SHAPE-B



T12-B2 SHAPE-0.5B



T12-BL SHAPE-BL

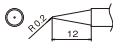

T12-BC1 T12-BCF1



T12-BC2 T12-BCF2

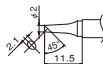

T12-BC3 T12-BCF3



T12-C1 SHAPE-1C



T12-C4 T12-CF4



T12-D08 SHAPE-0.8D



T12-D12 SHAPE-1.2D



T12-D16 SHAPE-1.6D



T12-D24 SHAPE-2.4D



T12-D4 SHAPE-4D



T12-D52 SHAPE-5.2D



T12-DL32 SHAPE-3.2DL

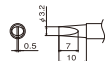

T12-I SHAPE-I



T12-IL SHAPE-IL



T12-ILS SHAPE-ILS



T12-J02 SHAPE-0.2J



T12-KU SHAPE-KU



T12-JL02 SHAPE-0.2JL



T12-JS02 SHAPE-0.2JS



T12-K SHAPE-K

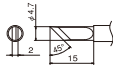

T12-KF SHAPE-KF

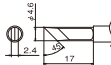

T12-KL SHAPE-KL



T12-KR SHAPE-KR



T12-BCM2 SHAPE-2BC



T12-BCM3 SHAPE-3BC



T12-1401



T12-1403

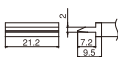

Note: Choosing the right iron tip can make the work more efficient.

## Iron tips maintenance

1. Please put appropriate tin on the adhering head of iron tip Before powering off , and please clean it before welding.
2. Do not allow the iron tip to stay at high temperature for a long time to avoid dry burning.
3. In welding, do not rub the soldering tip with too much pressure to friction the solder, which will damage the iron head.
4. Never clean iron head with a rough material or file.
5. If the surface oxide and no absorb tin, as needed you can use 600 to 800 of emery cloth friction it carefully and use isopropyl alcohol or equivalent solution to clean, heated to 200 °C immediately adhering tin to prevent sticking tin and then oxidation.
6. Do not use chlorine or high acid soldering flux. Only use of synthetic resin or activated resin flux.
7. The working temperature of the soldering iron tip is about 300 °C to 380 °C , and the working temperature should not exceed 450 °C in a short time. Otherwise it will affect the working life of the soldering iron tip!
8. Different welding scenes should be selected with different soldering iron tip. Large welding spot or aluminum base plates will need to be touched to large soldering iron tip (such as C4). Small welding spot can be used C1, JL02, ILS, etc.
9. The new soldering iron tip is used for the first time, the heat up may be slightly slower, and it can melt tin 7 seconds after the normal use of 1-3 hours.
10. 7 seconds of tin, only for solder wire with the high purity and low melting point, the higher the lead tolerance, the speed of melt tin is slower, the higher the temperature will be required. So we suggest to choose the high purity & low melting point solder wire from my store.

## After-sales service

T12 soldering station host in non-human damage to provide 1 year free warranty service. Warranty service, please contact the seller to buy! Iron head is a consumables, its life and maintenance of the tip, the use of the number of the first use can not be returned or replacement.

## About Discarding



**Do not discard in family garbage!**

Handling and recycling: you have to deal with the iron correctly according to local laws and regulations.

**FAQ:****1. Why the temperature of the new T12 solder tip is jump?**

Because the inside heating core of the new T12 solder tip did not go through the high temperature, so the first time to use will be a bit of temperature, generally without special treatment, the normal use of 1-2 days after the basic will not bounce. Such as the need to immediately effective, the general proposal to adjust the temperature to 380°C -400°C, side of the solder tip to the tip of tin, burning 5-10 minutes after the shutdown, until the solder tip of the cooling and then re-boot! ( if 1 times no effect, then can be repeated 2-3 times). T12 is pulsating temperature warming, even if the display temperature is flashing, the tip of the real temperature is completely stable.

T12 jump temperature also are connected with the temperature control board of procedures, power of electrostatic and if it connect the ground.

**2. What the problem of attention when we use the T12 first time?**

T12 tip heating speed is very fast, when the new solder tip connect the electricity, it must be tinput immediately to the solder tip, for protection, due to heating up fast, just need 6-10 seconds, no have more time to you for preparation.

so the important is prepare the items which will be welded, and finally boot power, and each welding gap or the end, should be more on the tin to protect and then shutdown, so it can avoid to tin the new sold tip is difficult, especially the T12 tip type of iron, such as T12-I / T12-IL / T12-BL / T12-ILS and so on!

**3.What are the precautions for using the T12 tip?**

a. If can use low temperature, then do not high temperature: T12 is constant temperature control, the general recommended working temperature control between 300°C ~ 380°C, higher than 380°C damage the coating of solder tip and cut down the PTC life!

b. Do not dry: the first time to use solder tip, should be wrapped while heating a layer of tin. If it's without work, at once shutdown!

c. Diligent to clean: before shutting down, use a wet sponge or detin the ball to remove the tip of the oxidation of debris, on the tin after the shutdown power off!

d. Standard operation: Do not violent collision the solder tip, do not stamp the top of the hard objects, but can not be used to hot plastic and other materials, specifically reminded that friends like tin should avoid the iron and other hard metal knock tin, the heating core of T12 is in the head of the solder tip, often percussion is a fatal damage to T12!

e. Less use of scaling powder: scaling powder can not be used, can be used as less as possible! When scaling powder help make beautiful and reliable welding at the same time, but also greatly speed up the consumption the coating of the solder tip, T12 heating core high temperature position is very near of the Nozzle tip of the solder tip,Scaling powder in the fear of threat to T12 head pressing parts.

**4.How to do when T12 tip does not absorb tin?**

T12 iron head does not absorb tin, generally there are two reasons:

A. The head of solder tip is severe oxidation can not absorb tin.

B. Temperature can not rise up then can not tin.

C. The head is oxidized and can not the tin, you can use the soldering iron to clean the ball gently, then use the wet sponge rub and then heat the tin.

# QUICKO

Your feedback will make us better!



Chinese website



Taobao



Aliexpress

Made in China

Quicko electronic co.,ltd TEL:08615992468682